

MONTEREY ON THE LAKE

WELLINGTON - P. U. D.

SHEET 5 OF 6 SHEETS

BEING A REPLAT OF LAKE WELLINGTON ESTATES, P. U. D.: WELLINGTON - P. U. D.
AS RECORDED IN PLAT BOOK 63, PAGES 18 AND 19, OF THE PUBLIC RECORDS OF
PALM BEACH COUNTY, FLORIDA.

AUGUST 1992

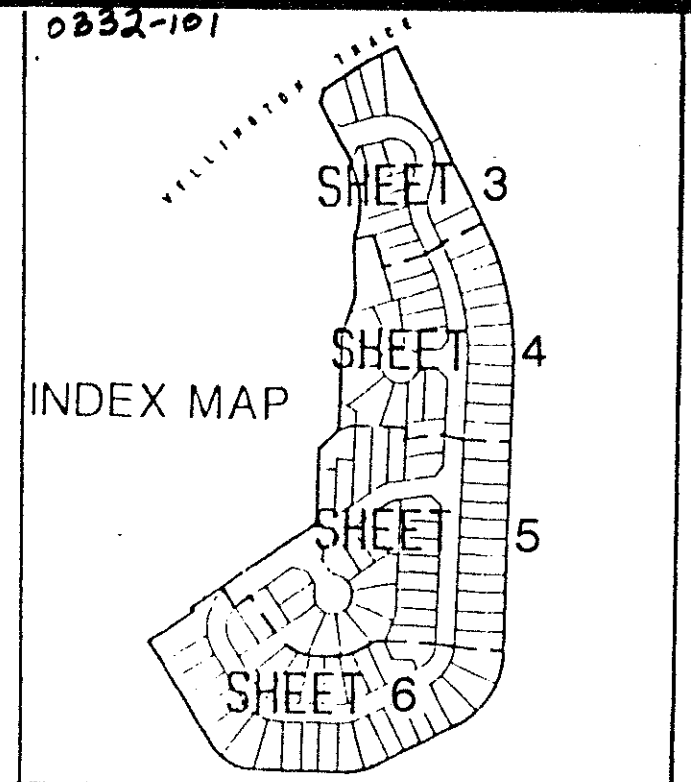

18

- LEGEND**
- O.R.B. = OFFICIAL RECORD BOOK
 - R/W = RIGHT-OF-WAY
 - P.B. = PLAT BOOK
 - PGS. = PAGES
 - MAINT. EASE. = MAINTENANCE EASEMENT
 - P.U.D. = PLANNED UNIT DEVELOPMENT
 - L.A.E. = LIMITED ACCESS EASEMENT
 - A = ARC LENGTH
 - Δ = CENTRAL ANGLE
 - R = RADIUS
 - C = CENTERLINE
 - D.U. = DWELLING UNIT
 - P.L.S. = PROFESSIONAL LAND SURVEYOR
 - P.C.P. = PERMANENT CONTROL POINT
 - P.R.M. = PERMANENT REFERENCE MONUMENT
 - R.E.E. = ROOF ENCROACHMENT EASEMENT
 - = DENOTES ZERO LOT LINE
 - P.C.C. = DENOTES POINT OF COMPOUND CURVATURE
 - P.R.C. = DENOTES POINT OF REVERSE CURVATURE
 - A.I.D. = ACME IMPROVEMENT DISTRICT

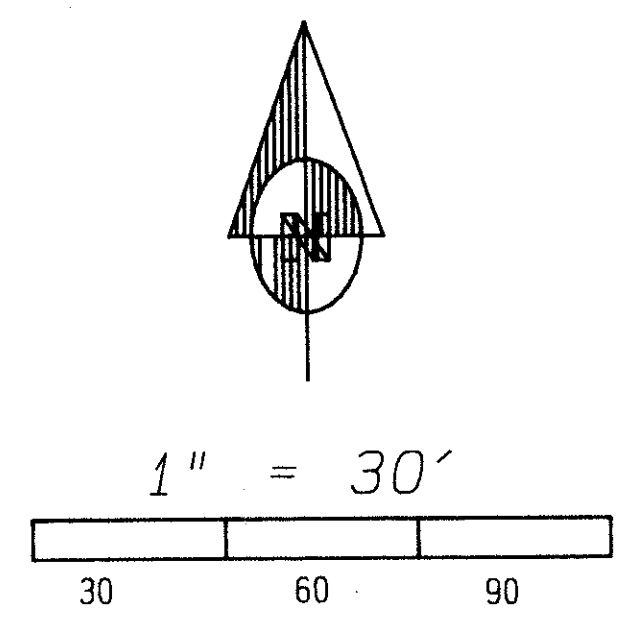

PARCEL "A"; TRACT 38
FOREST CLUB OF
WELLINGTON - PUD
(P. B. 52; PGS. 130-132)

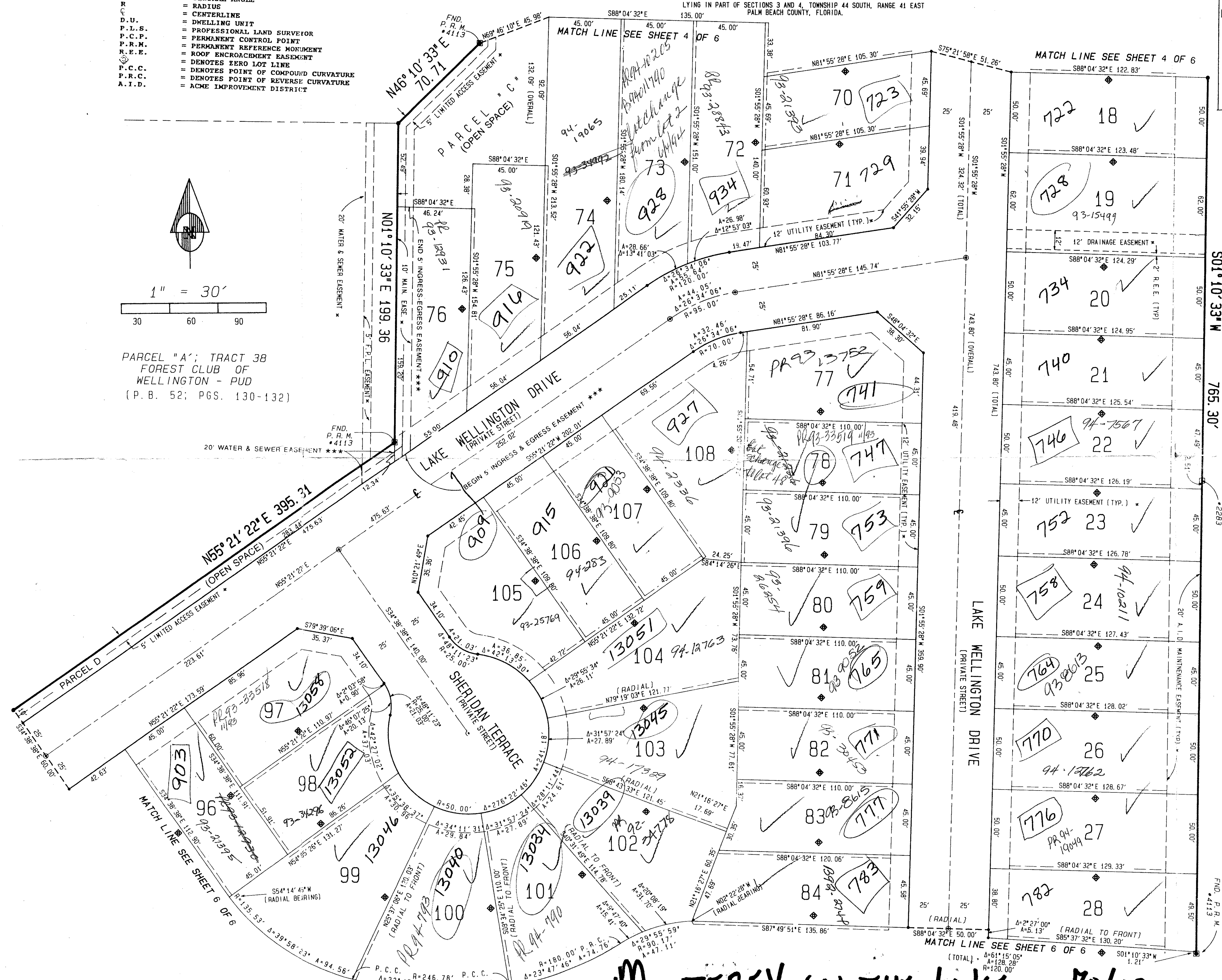

ACME IMPROVEMENT DISTRICT C-7
(O.R.B. 2501; PGS. 1230-1231)

SUBDIVISION * Monterey on the Lake
BOOK 70 PAGE 18
FLOOD ZONE B FLOOD MAP # 100B
QUAD # 62,77 ZONING AK
SE ZIP CODE 33414
PUD NAME Wellington P.U.D.
#4113

TAZ = 727

PET. 96-32H
COLLECT

0332-101

MONTEREY ON THE LAKE 70/18

Dailey-Fotony, inc.
land surveyors, planners, engineers
5050 10th Avenue North, Suite A - Lake Worth, Florida 33463-2602
Phone 407/965-8787